

# Mark 908X Series

## 1/2" - 3/4" Low Pressure Blanketing (Gas overlay) PRV for small Stainless and SUD vessels

The Mark 908X Series regulator was designed specifically to provide accurate pressure control on very low pressure vessel blanketing in stainless steel and single use systems.

The Mark 908X has a large bore sensing line connection on the bottom of the actuator. Regulated outlet pressure is directly tubed to the underside of the very large main control diaphragm. Consequently, it responds to very small changes in tank pressure by throttling open or closed to maintain the desired pressure set point.

- All 316L barstock construction
- FDA and USP Class VI Compliant elastomers and fluoropolymers
- Direct Operated
- Fully Balanced Plug
- Accurate regulation down to 1/2" wc (1.25 mbar)
- ANSI Class VI Shutoff
- Four spring ranges for set points between 1.25 and 103,4 mbar
- 200 psi maximum inlet pressure
- Three Cv's (Kv's): 0.15, 0.2, 0.4 (0,13, 0,17, 0,35)
- Ultra Lightweight PTFE Diaphragm for Maximum Sensitivity

### OPTIONAL FEATURES

- Inlet Gauges: 0-100, 0-200
- Purge Feature
- Optional High Alloys Available
- Optional End Connections Available
- Outlet Check Valve
- O<sup>2</sup> or Oil Free Cleaning



### APPLICATION:

Pressure reducing valves for regulating very low flow, low pressure clean compressed air and gas point of use applications in stainless steel and *single use disposable vessels* for the Biopharmaceutical, Pharmaceutical, Food & Beverage and Consumer Health & Beauty industries:

- Stainless steel bioreactor/fermenter: very low pressure sparge and purge/blanket/motive force gas regulation
- Single use disposable bioreactor/fermenter: very low pressure sparge and purge/blanket/motive force or integrity testing gas regulation
- Separation: Purge/blanket/motive force gas regulation and bag integrity testing for process vessels
- Purification: Purge/blanket/motive force gas regulation and bag integrity testing for process vessels
- Formulation: Purge/blanket/motive force gas regulation and bag integrity testing for process vessels
- F & B Consumer H & B process purge/blanket/motive force gas regulation

## SPECIFICATIONS

### Sizes:

- 1/2" – 3/4" (DN15 – DN20)

### End Connections:

- ASME BPE Tri-Clamp - standard
- DIN or ISO Tri-Clamp - optional
- FNPT - optional
- ANSI & DIN Flanges - optional

### Body Materials:

- ASTM A479 316L Stainless Steel
- Other Materials Available on Application

### Spring Housing:

- 316 Stainless Steel

### Diaphragm:

- Ultra Lightweight PTFE (FDA and USP Class VI compliant)

### Seats, O-rings and Balance Diaphragm:

- Viton (FDA compliant), EPDM (FDA and USP Class VI compliant)

### Gaskets:

- PTFE (FDA and USP Class VI)

### Shutoff:

- ANSI Class VI

### Available Spring Ranges

- 0.5 – 5.5 wc (1.24 - 13.69 mbar)
- 4 – 10 wc (9.95 - 24.88 mbar)
- 8 – 15 wc (19.91 - 37.33 mbar)
- 0.5 – 1.5 psi (34.47 - 103.42 mbar)

### Max Operating Inlet Pressure:

- 200 psig (13,79 barg)

### Max Differential Pressure:

- 200 psig (13,79 barg)

### Max Downstream Pressure (Safety Rating):

- 20 psig (1,38 barg)

### Max Operating Temperature:

- 250°F (121.1°C)

### Weight (with Tri-Clamp ends):

- 20 lbs (9.1kg)

### Surface Finish:

- Internal Wetted Parts 20 Raµm (.5Raµm) electropolished
- External Wetted Parts 40 Raµm (1.0 Raµm)
- Other Finishes Upon Request

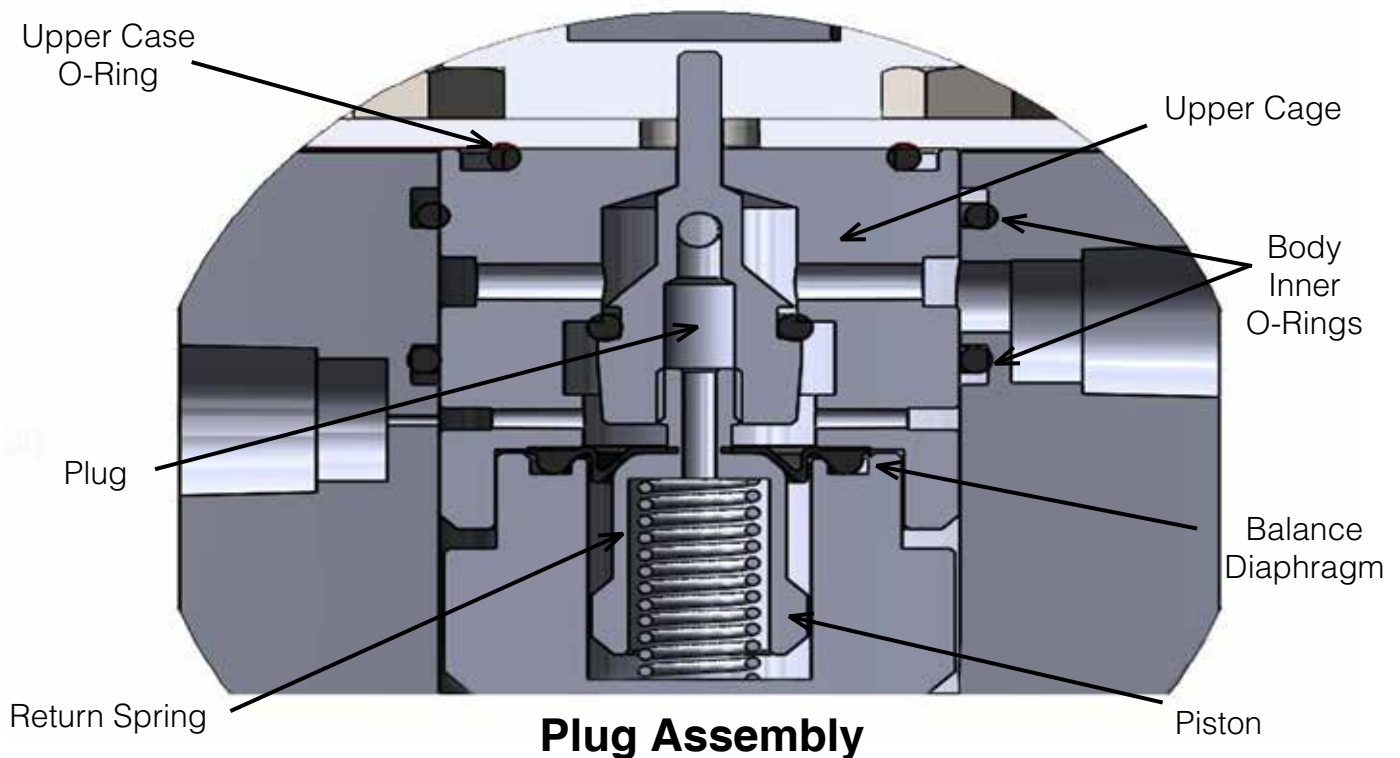

## DIMENSIONS

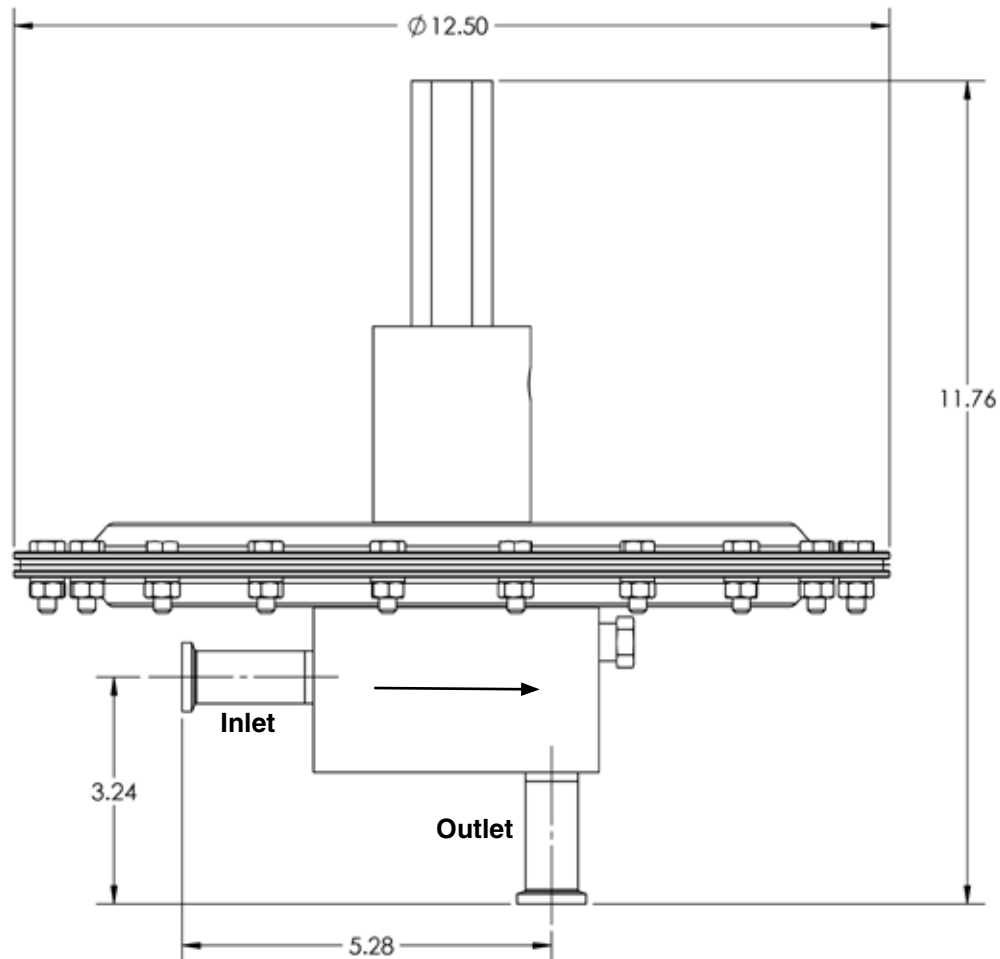

## Sizing and Cv Selection Instructions

### For blanketing applications:

1. Adjust the flow rate requirements given to you from the tank owner, by following the API 2000 vessel blanketing guidelines in our document I&M section (if not already completed by the owner).
2. Select a MK908X Cv (.15, .2, or .4) by using the "Globe" sizing in our SFCV sizing software for calculated Cv's  $\geq .2$ , and the "Low Flow" sizing for calculated Cv's  $\leq .2$ . Select a valve Cv so that the calculated Cv does not exceed 90% of that value.

### For applications other than vessel blanketing (low flow/low pressure gas line regulation, Single use disposable bag inflation, sparging, etc):

1. Select the Cv by using the "Globe" sizing in our sizing software SFCV for calculated Cv's  $\geq .2$ , and the "Low Flow" sizing for calculated Cv's  $\leq 2$ . Select a valve Cv so that the calculated Cv does not exceed 90% of that value.

**ORDERING SCHEMATIC**

	—		—	/	1 & 2	3 & 4	5 & 6	7 & 8	9 & 10	11 & 12

Model	
908X	ASME BPE Tri-Clamp Connections

Size	
050	1/2"
075	3/4"

Material	
SB	Stainless Steel (SA479)
ZZ	Non-Standard

1 & 2	End Connections & Cv		
C	Tri-C	A	0.15
		B	0.20
		C	0.40
ZZ	Non-Standard		

3 & 4	Seat & O-Ring
V1	Viton (FDA only)
EP	EPDM (FDA and USP CL VI)
ZZ	Non-Standard

5 & 6	Press Switch
AA	Not Req'd
ZZ	Non-Standard

7 & 8	Range
A7	0.5 – 5.5 wc (1.24 - 13.69 mbar)
A8	4 – 10 wc (9.95 - 24.88 mbar)
A9	8 - 15 wc (19.91 - 37.33 mbar)
B1	0.5 - 1.5 psi (34.47 - 103.42 mbar)
ZZ	Non-Standard

9 & 10	Actuator
S1	Standard
ZZ	Non-Standard

11 & 12	Accessory
SC	Clean for Oil Free Service
XC	Clean for Oxygen Service
AA	EN10204 3.1 Cert All Wetted Parts
ZZ	Non-Standard Option

*Steriflow Valve reserves the right to make revisions to its product, specifications, literature and related information without notice. Please visit our website at [www.steriflowvalve.com](http://www.steriflowvalve.com) for the latest information on our products.*



**Steriflow by Jordan Valve**

3170 Wasson Road • Cincinnati, OH 45209  
 513.533.5600 • 800.543.7311 • 513.871.0105 (f)  
[steriflow@richardsind.com](mailto:steriflow@richardsind.com) • [www.steriflowvalve.com](http://www.steriflowvalve.com)